

INSTRUCTION SHEET



BATTERY SWITCHES

BATTERY DISCONNECT SWITCH

This battery disconnect is intended to disable the vehicle with an alternator in the event of an emergency. The following diagram is intended for reference only. Due to the many different applications and variations of components, it is the responsibility of the installer to verify correct connections. We recommend the use of a single wire alternator to simplify installation.

CONNECTIONS

The larger 3/8" terminals are for main battery to starter connections only. The smaller 10-32 studs provide a separate circuit for alternator use. A wire the same size as the charge wire to the alternator can be used to supply power to the alternator if it is connected to the battery side of the disconnect, as illustrated in the diagram. The charge wire size is determined by the alternator rating and length of wire connecting the alternator to the battery, this information is available from most alternator manufacturers.

WIRING DIAGRAM

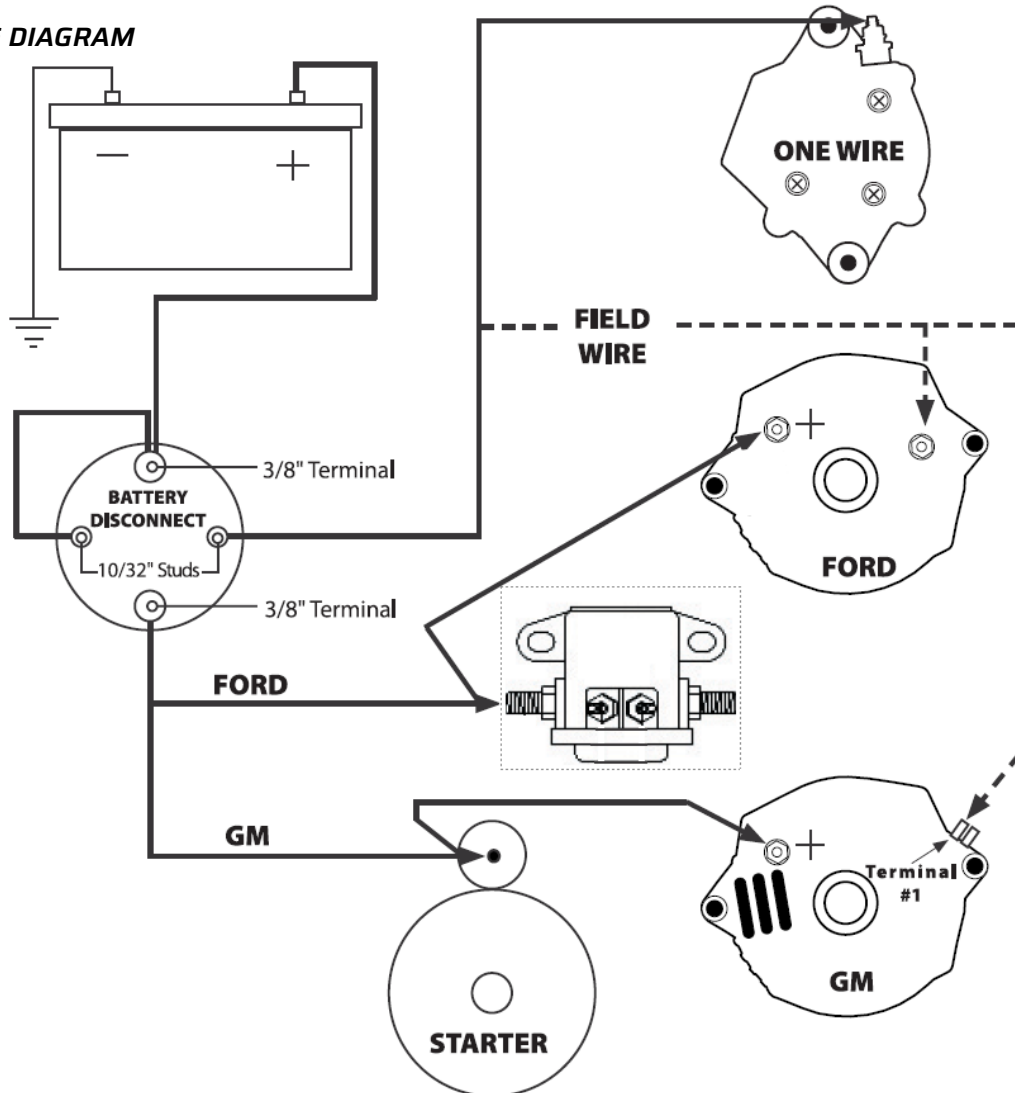

REV.10-24

⚠ WARNING: This product can expose you chemicals including lead, which is/are known to the state of California to cause cancer, birth defects or other reproductive harm. For more information, go to: www.P65Warnings.ca.gov

